

Vantage LED Beacons

Features

- Aesthetic Modern Design
- Low Power Consumption
- Choice of Flash Frequency
- Choice of Lens Colours
- All-round Visibility
- Bayonet Fixing Mounting Base
- Waterproof version (Deep Base)

Description

Designed as a general purpose LED beacon for fire, security and industrial applications, the Vantage Beacon incorporates the latest in energy efficient LED technology to provide maximum all-round visibility in an aesthetically pleasing body with minimum power requirements.

The Vantage LED Beacon is available in a choice of lens and body colours and is offered with either a shallow base for rear cable entry or a deep base to facilitate both rear and surface cable entry. Quick fit installation is achieved by the bayonet fixing arrangement on both types of mounting base, which includes a locking feature, with cable termination being made via 45° terminals located on the underside of the beacon.

Dimensions

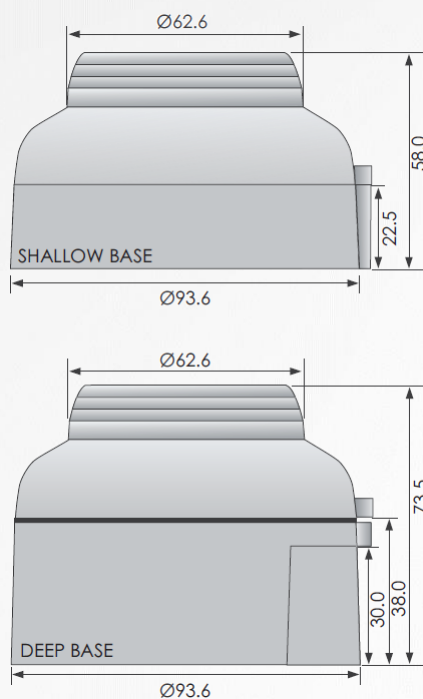

Vantage LED Beacons

Item Numbers

Item No	Description
4107-1001	Red LED Beacon White Shallow Body
4107-1002	Amber LED Beacon White Shallow Body
4107-1003	Red LED Beacon White Deep Body
4107-1004	Amber LED Beacon White Deep Body
4107-1009	Red LED Beacon Red Deep Body
4107-1010	Amber LED Beacon Red Deep Body
4107-1011	Clear Lens Red LED Beacon White Shallow Body
207-0042	Beacon Sign Plate FIRE

Specifications

Operating Voltage	9 - 48V DC
Supply Current	9mA @ 24Vdc
Flash Rate	T3 Temporal (red & clear) 1Hz (amber)
Operating Temp.	-20°C +70°C
Humidity	0 to 95% Non-condensing
Material	ABS fire retardant plastic
Dimensions	
Shallow Base	94mm \varnothing x 58mm H
Deep Base	94mm \varnothing x 74mm H
IP rating	IP43 (shallow) IP65 (deep)
Weight	145g (shallow) 165g (deep)